

CLUTCH BOLT PATTERN PAGE

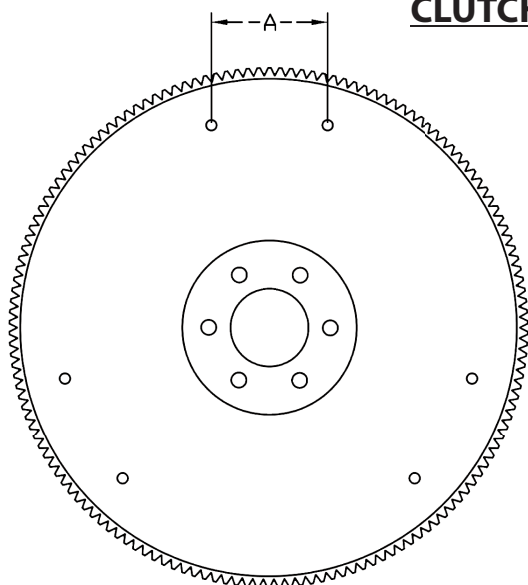

TYPE 1

3 GROUPS OF 2 BOLT PATTERN
MEASURE BETWEEN 1 GROUP FROM
BOLT HOLE CENTERS

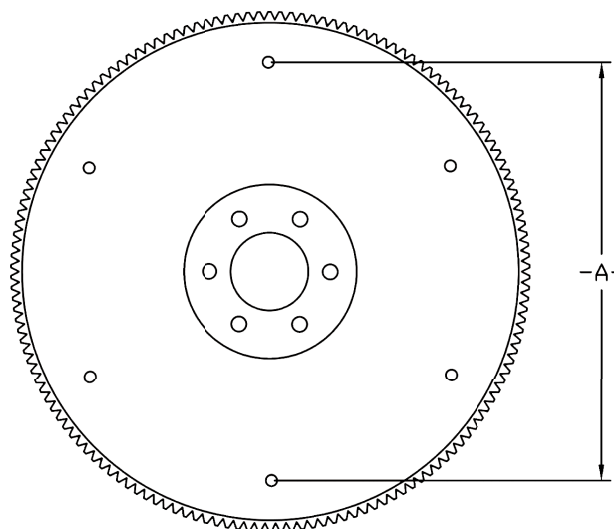

TYPE 2

EVENLY SPACED BOLT PATTERN
MEASURE BOLT HOLES DIRECTLY ACROSS
FROM BOLT HOLE CENTERS

CLUTCH PATTERN	TYPE	DIMENSION "A"	BOLT SIZE	DOWEL PINS
#1 8-1/2" FORD	2	9-11/16"	5/16" X 18	
#2 10" - 10.4" GM/CHRYLSER	2	11-5/8"	3/8" X 16	
#3 11" - 12" GM/CHRYLSER	2	12-5/8"	3/8" X 16	
#4 10" - 10-1/2" FORD	1	3-1/8"	5/16" X 18	
#5 11" FORD	1	3-3/8"	5/16" X 18	
#6 11-1/2" FORD	1	3-9/16"	5/16" X 18	
#7 10.4" MUSTANG 1986 - UP	2	11-3/8"	8mm X 1.25	YES
#8 11" FORD DIAPHRAGM	2	12-3/8"	3/8" X 16	
#9 215mm / 8-1/2" MAZDA	2	9-11/16"	5/16" X 18	
#10 225mm / 8-7/8" MAZDA	2	9-59/64"	5/16" X 18	
#11 240mm / 9-7/16" MAZDA	2	10-7/8"	5/16" X 18	
#12 236mm / 9-1/8" TOYOTA	2	10-43/64"	8mm X 1.25	YES
#13 220mm/ 8-5/8" ACURA / HONDA	2	9-47/64"	8mm X 1.25	YES
#14 11"-11-1/2" GM LS1	2	12-5/8"	10mm X 1.50	YES
#15 212mm/ 8-3/8" HONDA	2	9-25/64"	8mm X 1.25	YES
#16 10.4" PANTERA CONVERSION	2	11-3/8"	3/8" X 16	
#17 225mm EAGLE / MITSUBISHI	2	9-23/32"	8mm X 1.25	YES
#18 11" OHC MUSTANG 4.6L	2	12-43/64"	10mm X 1.50	YES
#19 9-1/8" V8 FIERO CONVERSION	2	10-9/16"	5/16" X 18	
#20 220mm/ 8-5/8" HONDA	2	10"	8mm X 1.25	YES
#21 236mm/ 9-1/4" TOYOTA	1	3-15/16"	8mm X 1.25	YES
#22 12-1/4" DODGE CUMMINS 4 GROUPS OF 2	1	3-33/64"	5/16" X 18	
#23 13" DODGE CUMMINS 4 GROUPS OF 2	1	3-21/32"	5/16" X 18	
#24 11" GM PULL-TYPE	2	11-5/8"	3/8" X 16	
#25 224mm/ 8-7/8" TOYOTA	1	4-11/16"	8mm X 1.25	YES
#26 240mm/ 9-7/16" MITSUBISHI	2	10-49/64"	8mm X 1.25	YES
#27 240mm/ 9-7/16" FORD FOCUS	2	10-15/64"	8mm X 1.25	YES

NOTE: ALL DIMENSIONS HAVE BEEN ROUNDED TO THE NEAREST FRACTION OF AN INCH AND ARE FOR REFERENCE ONLY.

FOR MORE INFORMATION PLEASE CONTACT CENTERFORCE ON OUR TECH LINE AT (928) 771-8422.